

# STELRON CAM COMPANY

1495 Mac Arthur Boulevard  
Mahwah, New Jersey 07430  
tel 201-529-5450 ~ fax 201-529-5493

## RD-5 SERIES PRE-LOADED CAM DRIVE MAINTENANCE INSTRUCTIONS

# Maintenance Instructions

Thank you for choosing a Stelron cam operated index drive or oscillator. You have indeed made a wise decision. Our engineers have gone to great lengths to include the many important features that enhance durability, serviceability and accuracy in your Stelron drive. The following are just some of those important features:

- 1) Hardened and CNC profile ground, extra large diameter cams operating in a sealed, oil filled housing.
- 2) Near machine tool quality crossed roller and 4 point contact type output bearings on RD provide superior life, overhung load and increased thrust capacity.
- 3) Standard NEMA "C" frame motors.
- 4) Heavy cast aluminum universal mounting housings with machined surfaces and mounting holes on five or six sides.
- 5) Heavy Duty swing arm type micro switches with large diameter steel signal cams.

### PRODUCT OVERVIEW

This is a pre-loaded type cam index drive with a hardened cam and precision needle bearing cam followers, operating in a sealed, oil filled housing. Two opposing cam followers contact the cam, eliminating backlash. The acceleration profile is modified sine, unless otherwise specified.

### WARNINGS TO THE USER

This unit is sized and warranted to handle a specific dynamic load. Loads will increase with the square of the index time (or camshaft RPM). Index speed can markedly affect product life. Never run this unit faster than originally intended without checking with Stelron first.

Backlash on the input or output of the unit will introduce "jerk" into the system, decreasing life and performance. Always try to minimize backlash.

Any overload devices, whether provided by Stelron or not, cannot claim to protect humans from harm. These devices are meant to protect specific machine components from harm only.

Cycling on demand any faster than the control manufacturer specifies (30 cycles per minute for Danfoss #C-2000 and KB Electronics #KB-PI; 60 cycles per minute for Danfoss Cycletrol 150) will void control warranty and may cause premature failure. Please consult Stelron if your cycling requirements exceed those mentioned above.

### LUBRICATION INSTRUCTIONS

The crossed roller output bearings on the RD series indexers are sealed and require no attention. The reducer sump lubricates all reducer bearings via slinging action of the gears. The interference fit between the cam and followers (and the close fit in Stelron low backlash reducers) dictates the use of an extreme pressure type lubricant in the index drive and reducer sumps. We recommend only Mobilgear 600 XP - 460 or Mobil SHC 634 Synthetic Gear Oil for Stelron indexers. This lubricant is available from your local Mobil distributor or Stelron.

The following schedule should be adhered to:

- One shift operation - Change lubricant every twelve months.
- Two shifts operation - Change lubricant six months.
- Three shifts operation - Change lubricant every three months.
- Higher speeds, dirty or high heat conditions may require more frequent lubricant change intervals.

### INPUT AND OUTPUT (DIAL) CONNECTIONS

All input and output connections should be tight and free of backlash or windup. Always oversize due to the reversing loads imposed by most cam mechanisms. In synchronous machinery, oversized timing belts with as large diameter as possible pulleys should be used. Taperlock or Ringfedder hubs are preferred. Worm gear reducers are preferred due to their inefficiency in backdriving and low backlash.

Dial plates should be bolted and doweled to the indexer. The pilot bore (ID) of the dial should be dimensioned to the nominal size of the indexer pilot  $+0.001"$ ,  $-0.000$ .

### OVERLOAD CLUTCH ADJUSTMENT

Stelron index drives and oscillators are equipped with two types of overload protection:

- 1) Internal Output Clutch (RD series)

A separate instruction sheet is included for the slip clutch in the gear reducer (#2). Stelron's Internal Output Clutch (#1) utilizes two or three ball individually adjustable ball-detent type "spring towers" that protrude through clearance holes in the dial plate. The dial mounting surface turns independently (on its own crossed axis roller bearing) of the main follower wheel when an overload is encountered. Adjustment of the trip torque is accomplished by use of a spanner wrench in the discs on top of the spring towers.

Adjustment should be done under the actual load of the drive at the actual production running speed. Try to tighten each of the spring towers approximately the same. The shafts in the middle of the clutch will pop up when the clutch disengages. A plate may be used to span these shafts and trip a limit or prox switch that shuts the input drive off. The dial plate must be re-positioned and the shafts must be pushed back down to re-engage the clutch. No further maintenance or care is needed once the clutch is set.

## TROUBLE SHOOTING

Unit Does Not Stop In Position or Positioning is Erratic-

Make sure unit is in dwell. This is the most common cause of problems in cam indexers. Rotate camshaft until movement has stopped on output. Rotate in same direction another 15 degrees. Unit should now be in dwell. Grab output of indexer and try and rotate. There should be no movement. If there is no movement, the signal cam may need to be adjusted or the indexer may be out of time (in a synchronous machine). The signal cam should send a stop signal so the motor stops the camshaft consistently in the dwell of the cam. Positioning problems occur when the motor stops the camshaft out of the dwell position. If there is movement detected when the unit is in dwell, there may be an internal problem in the indexer, usually bent or worn followers. First check that all input and output connections to the drive are tight and free of windup and backlash. Also check output clutch settings. See repair instructions below if all connections are tight and clutch is set properly.

Motion Is Not Smooth -

Make sure there is no backlash or windup in both the input and output couplings. Indexers and oscillators exert a reversing torque on both input and output connections. Any looseness shows up as erratic motion and can significantly shorten life.

## GENERAL REPAIR INSTRUCTIONS

Cam follower replacement on your Stelron RD series index drive is straightforward thanks to the barrel cam design. Since the pre-load is ground into the cam, pre-load adjustment is not required upon re-assembly. Proceed as follows:

- 1) Make sure indexer is in the dwell. Note that keyways on the input (cam) shaft of Stelron index drives are aligned with one of the junctions of index (motion) and dwell (stop). Turn the camshaft until output movement stops then turn at least another 15 degrees.
- 2) Make witness marks on the dial or machine member that attaches to indexer output and the indexer output flange. Plan to re-assemble exactly as you dis-assembled.
- 3) Remove dial or machine output member.
- 4) Remove the screws that hold the output bearing retainer in place.
- 5) Using the threaded holes provided, install jacking screws to separate the bearing retainer from the index drive housing.
- 6) Remove the bearing retainer. Note the number and color (thickness) of shims that you are removing.
- 7) Lift the entire output assembly out of the index drive housing. Carefully turn it over and set it down on a workbench.
- 8) Set screws lock the threaded stud followers in their bores. Loosen the setscrews then unscrew the cam followers.
- 9) Reinstall an entire new set of cam followers and lock them in place with the locking set screws.
- 10) Carefully place the output wheel back in the cavity in the indexer housing, engaging the two cam followers over the rib of the cam.
- 11) Replace the same number and color (thickness) of shims as removed.
- 12) Replace the bearing retainer ring and re-tighten the retaining screws.
- 13) Change indexer oil to remove any contamination.

The input shaft and output bearings in your Stelron index drive are considerably oversized relative to expected loads. They rarely require service of any kind. If replacement is required, please note the following:

- 1) The output bearings used on the RD series drives are pre-loaded by precision grinding the two housing halves. This means that the outside thickness of the bearing will vary and require shims under the bearing mounting ring. Measure the thickness of the bearing and compare this to the space in the cavity where the bearing fits. Use Stelron provided shims under the bearing retaining ring to make the resulting space for the bearing be .002-.005" less than the thickness of the bearing.
- 2) The Timken input shaft bearings use shims behind the bearing retainer caps to adjust the pre-load on these bearings. No side to side movement of the cam shaft is permitted. Shifting the cam in the housing will affect pre-load as well as positioning accuracy. Always measure the distance from a reference point on the housing to the dwell portion of the cam rib and hold this dimension upon re-assembling the camshaft back into the unit.

## REPAIR PARTS

A bill of materials is provided detailing all parts used in Stelron indexers. Commercially available parts are available from Stelron or the manufacturer. Special parts, on the bill of material, are available from Stelron only. Please call Stelron, or your local Stelron sales engineer, for any additional help in diagnosing possible index drive/oscillator problems.

---

### Lubrication Instructions for Indexers

RD-5:

Apply Mobilgear 600XP 460 (or equivalent) or Mobil SHC 634 Synthetic Gear Oil to half the cam height.

MotoReducers: All Models:

Apply Mobil Oil 600W (or equivalent) or Mobil SHC 634 Synthetic Gear Oil to fill level.

Note: On all oil filled components breather must be installed at the highest level for mounting position.

### Recommended Frequency of Inspection

#### Typical Usage

One Shift: Inspect at least once a month.  
Two shifts: Inspect once every two weeks.  
Three shifts: Inspect once a week.  
Severe duty: Inspect as often as necessary to maintain lubricity.

#### Lubrication

Mobil, U.S.A. Exxon, U.S.A.

or

**Stelron Components, Inc.** 1495 MacArthur Blvd., Mahwah, NJ 07430  
tel (201) 529-5450 fax (201) 529-5493

## RD-5 BILL OF MATERIALS

### MANUFACTURED PARTS

ITEM	P/N	QTY.	DESCRIPTION	MATERIAL / NOTES
1	RD-500	-	ASSEMBLY DRAWING/LAYOUT	-
2				
3	RD-501-P	-	HOUSING PATTERN DRAWING	"319" CAST ALUMINUM
4	RD-501	-	HOUSING (DETAIL)	RD-501P
5	RD-502	1	FOLLOWER WHEEL 12 POSITIONS	20.88 X 7" X 4.56 F.L. EZ-CUT 45
6	RD-503	1	FOLLOWER WHEEL 16 POSITIONS	20.88 X 7" X 4.56 F.L. EZ-CUT 45
7	RD-504	1	CAM SHAFT	2.9995 DIA. X OAL ~ 1144 G&P
8	RD-505	1	CAM (BLANK)	10" DIA. X 10.00 F.L. ~ C1144
9	RD-506P	-	BEARING RETAINER PATTERN	"319" CAST ALUMINUM
10	RD-506	1	OUTPUT BEARING RETAINER	RD-506P
11	RD-507	1	CENTER TUBE	7" OD X 6-1/2 ID X 15.75 F.L. DOM TUB'G
12	RD-308	2	ACCESS COVER	USE (2) RD-308 ~ LEXAN
13	RD-509	2	TIMKEN RETAINER CAPS	12" OD X 1.500 F.L. ~ 6061 ALUM.
14	RD-510	X	TIMKEN SHIMS	PLASTIC SHIM (ARTUS)
15	RD-411	12,16	BEARING RETAINER WASHER	1-5/8 DIA. X 3/8 F.L. CRS
16	RD-512	2	CONE MOUNTING PLATE	1.245 X 3" X 15" F.L. ~CRS
17	RD-516	X	THK. SHIMS	PLASTIC SHIM STK. (ARTUS)
18	RD-517	1	MICRO. SW. CAM (TYPE 2)	XXX DIA. X 3/8 LEDLOY
19	RD-518	1	MICRO SW. CAM (TYPE 1)	XXX DIA. X 3/8 LEDLOY
20				
21				
22				
23				
24				
25				
26				

### COMMERCIAL PARTS

ITEM	P/N	QTY.	DESCRIPTION
27	RB50040JUCC0	1	(THK) OUTPUT ROLLER BEARING (HI ACCURACY TYPE)
28	#66461	2	TIMKEN CUPS TAPER ROLLER BEARING CUP
29	#66225	2	TIMKEN CONES TAPER ROLLER BEARING CONE
30	#415254	2	(NAT'L) SEALS CAM SHAFT
31	#416364	1	(NAT'L) SEAL OUTPUT TUBE
32	405252	1	SEAL OUTPUT BEARING (VEE RING) (SKF C/R)
33	#AS-165	2	(NAT'L) TUBE O-RINGS
34	#AS-170	2	(NAT'L) COVER O-RING (SAME AS RD-3)
35	#AS-178	2	(NAT'L) TIMKEN RETAINER O-RING
36	KEY	1	1/2 X 1/2 X 4.75 F.L. KEY (CAM)
37	CNB-14	2	LOCK NUTS ~ (WHITTET - HIGGINS)
38	CCF-2.500-SB	12,16	HEAVY CAM FOLLOWER (McGILL)
39			
40			
41			

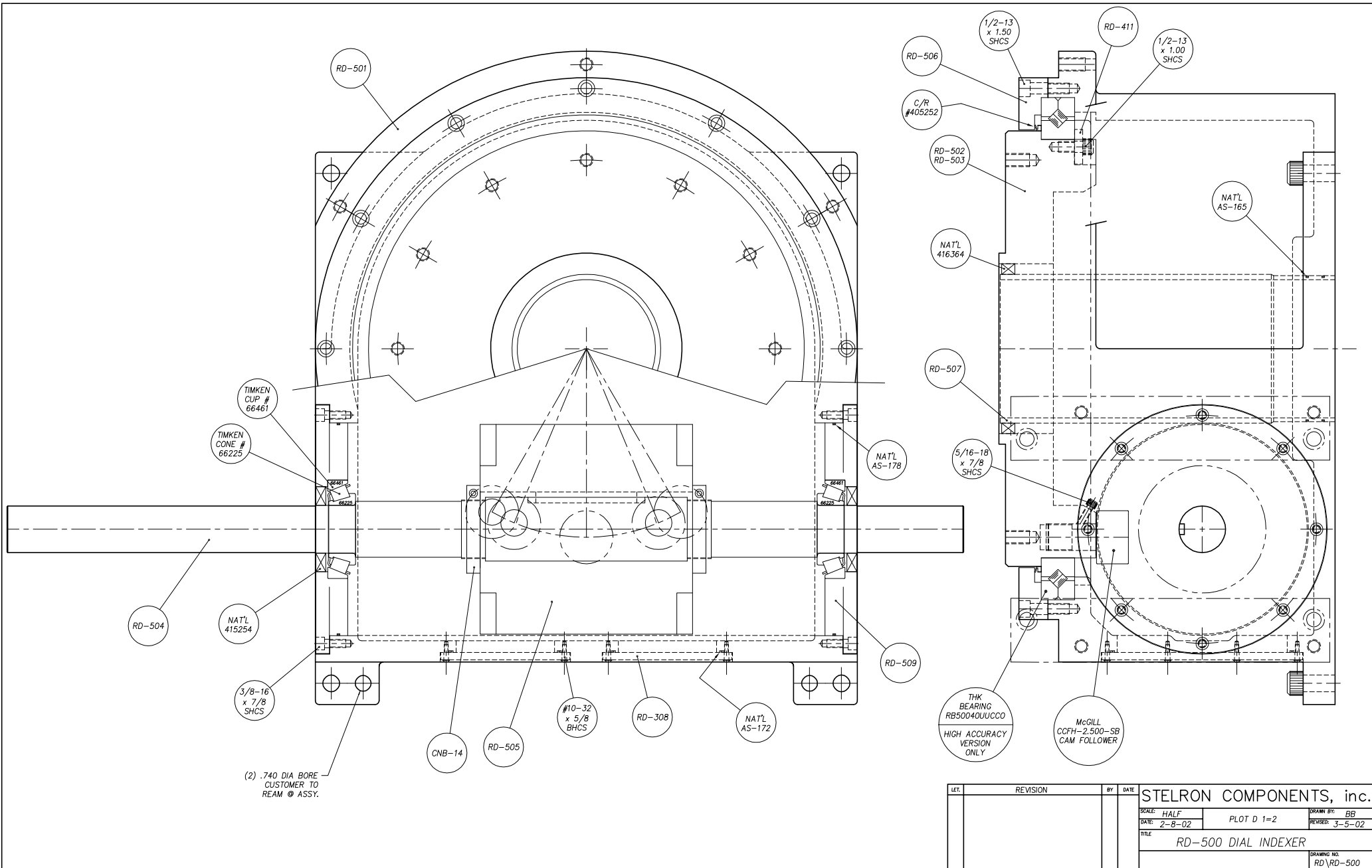

LET.	REVISION	BY	DATE

STELTRON COMPONENTS, inc.

SCALE: HALF	PLOT D 1=2	DRAWN BY: BB
DATE: 2-8-02		REVISOR: 3-5-02
TITLE: RD-500 DIAL INDEXER		
DRAWING NO. RD\RD-500		

## RD-5 (OUTPUT OVERLOAD) BILL OF MATERIALS

### MANUFACTURED PARTS

ITEM	P/N	QTY.	DESCRIPTION	MATERIAL / NOTES
1	RD-550	-	ASSEMBLY DRAWING/LAYOUT	-
2				
3	RD-501-P	-	HOUSING PATTERN DRAWING	"319" CAST ALUMINUM
4	RD-501	-	HOUSING (DETAIL)	RD-501P
5	RD-504	1	CAM SHAFT	2.9995 DIA. X OAL ~ 1144 G&P
6	RD-505	1	CAM (BLANK)	10" DIA. X 10.00 F.L. ~ C1144
7	RD-506P	-	BEARING RETAINER PATTERN	"319" CAST ALUMINUM
8	RD-506	1	OUTPUT BEARING RETAINER	RD-506P
9	RD-507	1	CENTER TUBE	7" OD X 6-1/2 ID X 15.75 F.L. DOM TUB'G
10	RD-308	2	ACCESS COVER	USE (2) RD-308 ~ LEXAN
11	RD-509	2	TIMKEN RETAINER CAPS	12" OD X 1.500 F.L. ~ 6061 ALUM.
12	RD-510	X	TIMKEN SHIMS	PLASTIC SHIM (ARTUS)
13	RD-411	12,16	BEARING RETAINER WASHER	1-5/8 DIA. X 3/8 F.L. CRS
14	RD-516	X	THK. SHIMS	PLASTIC SHIM STK. (ARTUS)
15	RD-517	1	MICRO. SW. CAM (TYPE 2)	XXX DIA. X 3/8 LEDLOY
16	RD-518	1	MICRO SW. CAM (TYPE 1)	XXX DIA. X 3/8 LEDLOY
17	RD-551	1	DIAL MOUNTING PLATE	20.88 OD X 7" ID X 3" ~ EZ-CUT 45
18	RD-552	1	FOLLOWER WHEEL (12 POSITION)	20.88 X 10" X 3" ~ EZ-CUT 45
19	RD-553	1	FOLLOWER WHEEL (16 POSITION)	20.88 X 10" X 3" ~ EZ-CUT 45
20	RD-555	1	BEARING RETAINER (INNER RACE)	10.8 X 7.7 X 1/2 ~ EX-CUT 20
21	RD-556	1	BEARING RETAINER (OUTER RACE)	14.5 X 11.25 X 1/2 ~ EZ-CUT 20
22	RD-558	X	GAP SHIMS	PLASTIC SHIM STOCK (ARTUS)
23				
24				
25				
26				

### COMMERCIAL PARTS

ITEM	P/N	QTY.	DESCRIPTION
27	RB50040JUCC0	1	(THK) OUTPUT ROLLER BEARING (HI ACCURACY TYPE)
28	#66461	2	TIMKEN CUPS TAPER ROLLER BEARING CUP
29	#66225	2	TIMKEN CONES TAPER ROLLER BEARING CONE
30	#415254	2	(NAT'L) SEALS CAM SHAFT
31	#416364	1	(NAT'L) SEAL OUTPUT TUBE
32	405252	1	SEAL OUTPUT BEARING (VEE RING) (SKF C/R)
33	#AS-165	2	(NAT'L) TUBE O-RINGS
34	#AS-170	2	(NAT'L) COVER O-RING (SAME AS RD-3)
35	#AS-178	2	(NAT'L) TIMKEN RETAINER O-RING
36	KEY	1	1/2 X 1/2 X 4.75 F.L. KEY (CAM)
37	CNB-14	2	LOCK NUTS ~ (WHITTET - HIGGINS)
38	CCF-2.500-SB	12,16	HEAVY CAM FOLLOWER (McGILL)
39	#RB25025UUC0	1	(THK) OVERLOAD BEARING ~ (SAME AS RD-2)
40	CR#402752	1	INTERNAL SEAL *NO LONGER USED-SEAL IS IN THK BRG
41	RD-570/RD-582	2 or 4	DETENT TOWERS (STELRON SPECIAL)

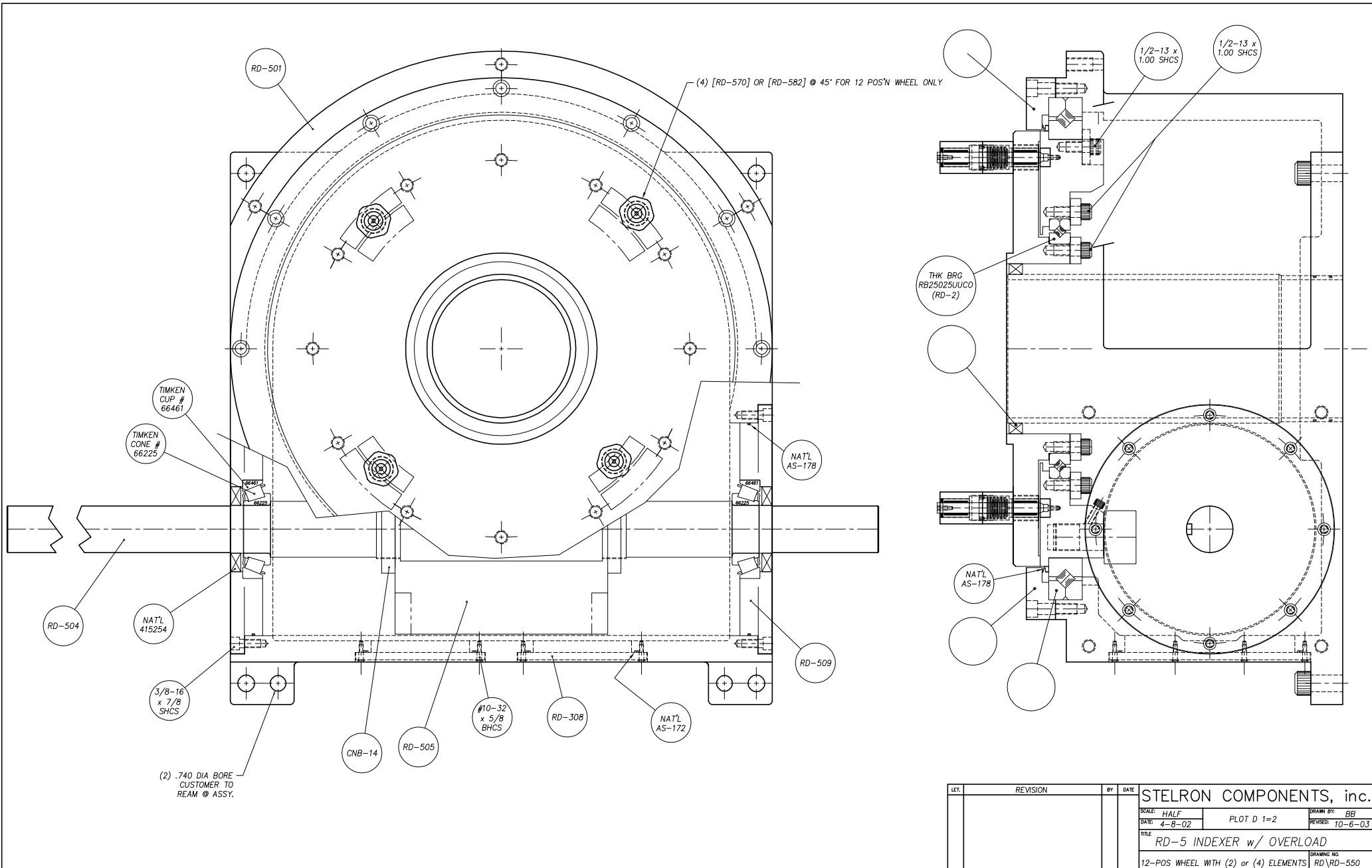

LET.	REVISION	BY	DATE

STELRON COMPONENTS, inc.			
SCALE: HALF	PLOT D 1=2	DRAWN BY: BB	
DATE: 4-8-02		REVISOR: 10-6-03	
TITLE: RD-5 INDEXER w/ OVERLOAD			
12-POS WHEEL WITH (2) or (4) ELEMENTS			DRAWING NO. RD\RD-550

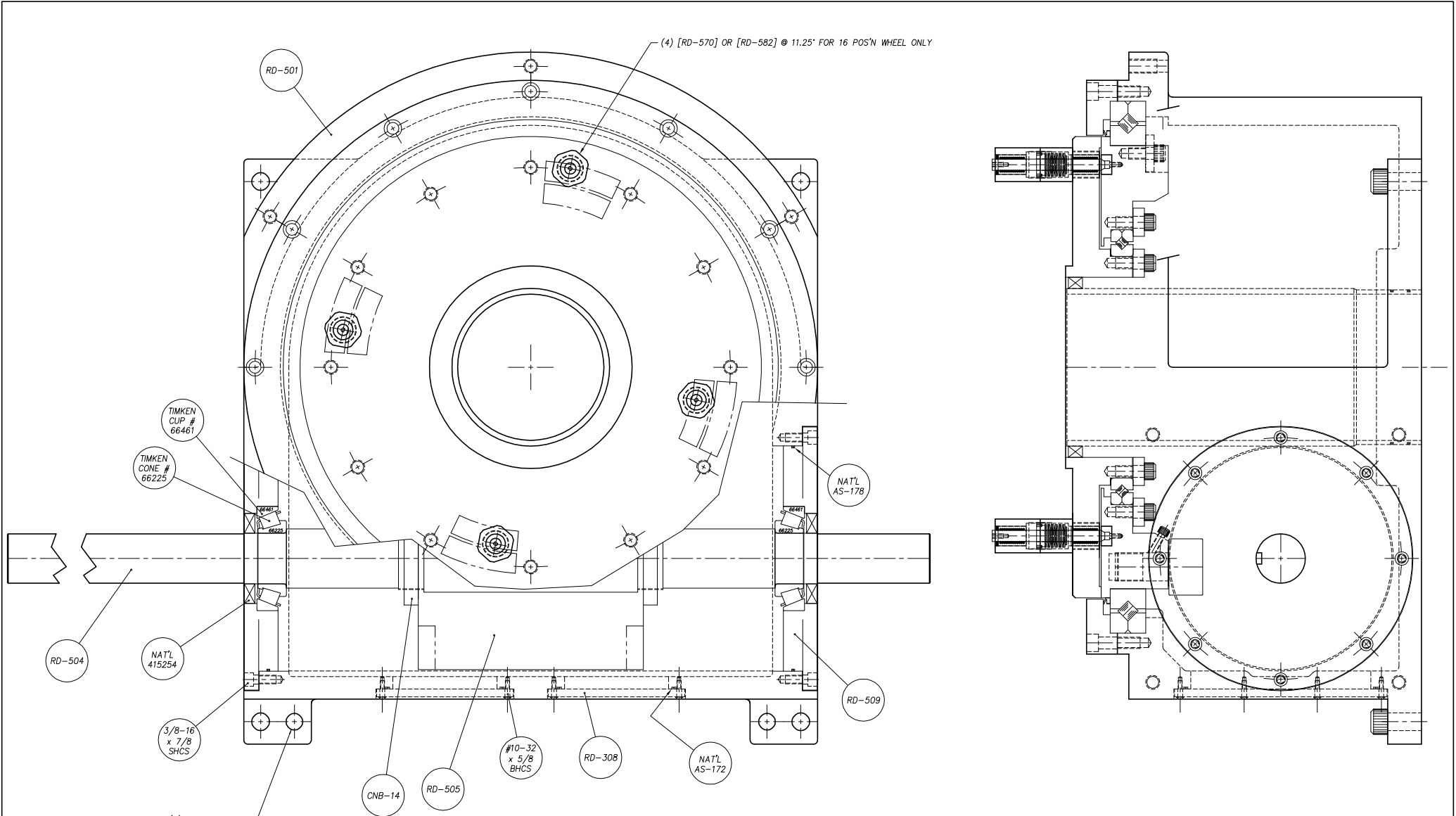

(2) .740 DIA BORE - CUSTOMER TO REAM @ ASSY.

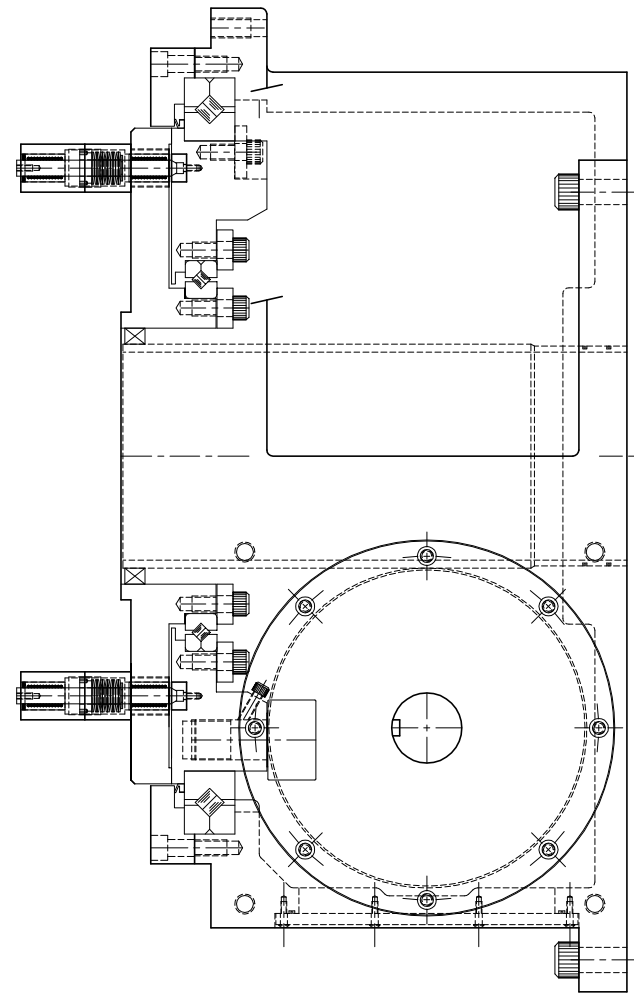

LET.	REVISION	BY	DATE	STELRON COMPONENTS, inc.		
				SCALE: HALF	PLOT D 1=2	DRAWN BY: BB
				DATE: 4-8-02		REVISOR: 10-6-03
				TITLE: RD-5 INDEXER w/ OVERLOAD		
				16-POS WHEEL WITH (2) or (4) ELEMENTS		
				DRAWING NO. RD\RD-550		

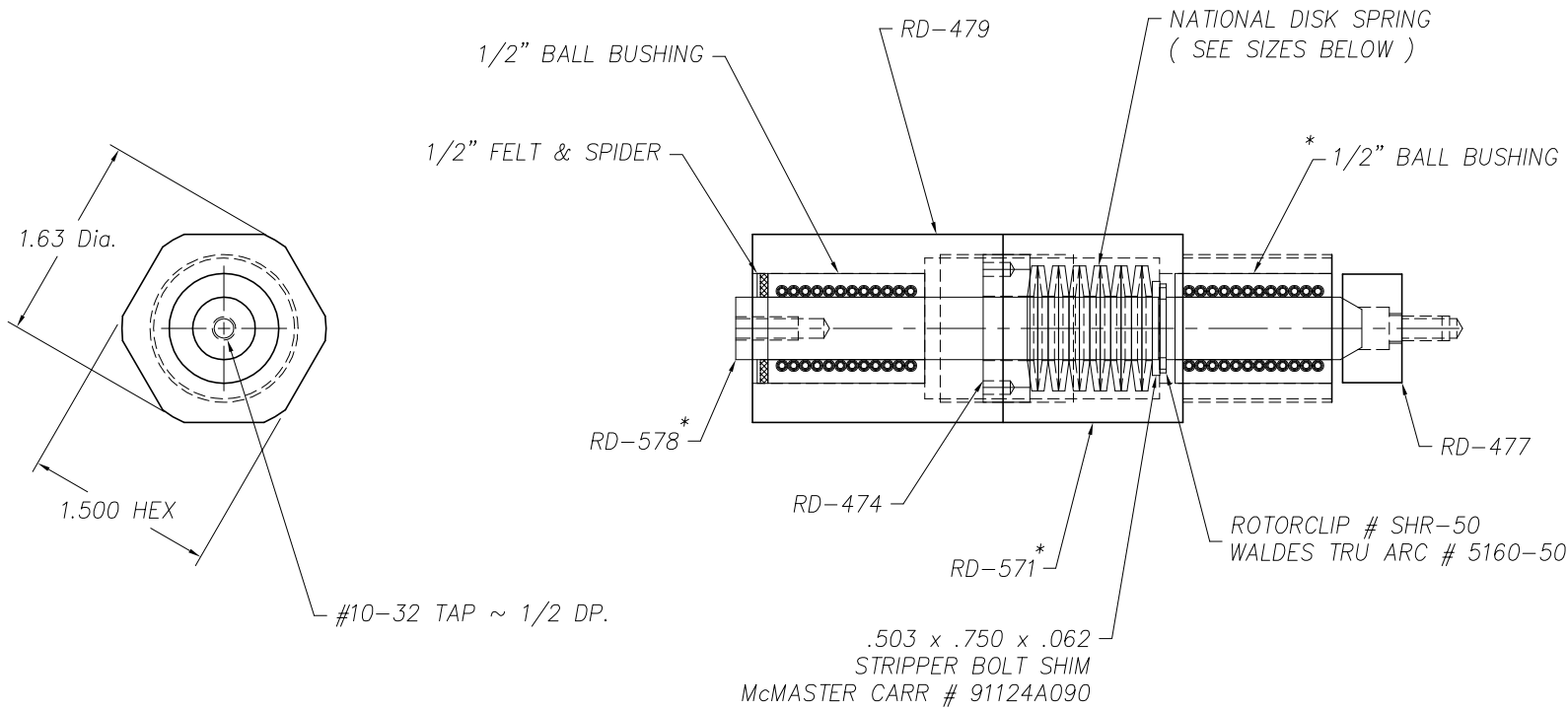

NATIONAL DISK SPRING OR EXACT EQUIVALENT

- # AI-105-135 (1.000 x .512 x .035)
- # AI-105-139 (1.000 x .512 x .039)
- # AI-105-149 (1.000 x .512 x .049)
- # AI-105-159 (1.000 x .512 x .059)

\* SAME AS RD-470 EXCEPT A LONGER BODY (RD-571)  
 A LONGER PLUNGER (RD-578) & ADD'L BALL BUSHING

<b>STELRON COMPONENTS, inc.</b>		
SCALE: FULL	PLOT B 1=1	DRAWN BY: BB
DATE: 5-7-02		REVISED: 10/15/04
TITLE RD-500 OVERLOAD TOWER		
		DRAWING NO. RD-570



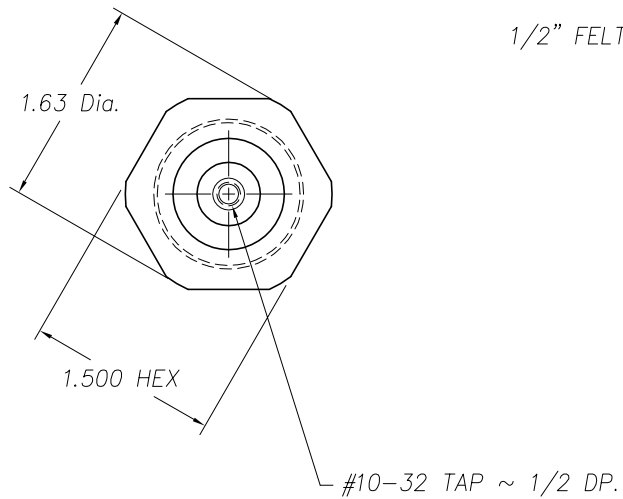

.5003 x .8765 x 1.00  
 DRILL JIG "P-BUSHING"  
 McMASTER # 8491A204

1/2" FELT & SPIDER

IRR # 100-50

RD-479

NATIONAL DISK SPRING  
 ( SEE SIZES BELOW )

RD-581

RD-474

RD-571\*

RD-477

.6253 x .8765 x 1.25  
 DRILL JIG "P-BUSHING"  
 McMASTER # 8491A521

NATIONAL DISK SPRING OR EXACT EQUIVALENT

- # AI-105-135 (1.000 x .512 x .035)
- # AI-105-139 (1.000 x .512 x .039)
- # AI-105-149 (1.000 x .512 x .049)
- # AI-105-159 (1.000 x .512 x .059)

STELRON COMPONENTS, inc.		
SCALE: FULL	PLOT B 1=1	DRAWN BY: BB
DATE: 8-30-07		REVISED: 9-27-07
TITLE RD-500 HD OVERLOAD TOWER		
		DRAWING NO. RD-582